

Aztec ADS430

Optical dissolved oxygen probe

EPA-approved optical dissolved oxygen measurement

Measurement made easy



Easy to use

- plug-and-play digital sensor connection
- automatic sensor recognition and set-up
- advanced predictive maintenance diagnostics
- supplied factory-calibrated ready for use

Accurate and reliable

- dynamic luminescence quenching technology eliminates sensor drift
- fast response time with patented signal processing
- robust construction provides abrasion and UV resistance

US EPA Approved

- US EPA approved technology for use in Clean Water Act programs
- suitable for use by NPDES permit holders for monitoring influent, effluent and treatment processes

Low cost of ownership

- long life sensor cap pre-loaded with factory calibration coefficients
- no need for on-site calibration
- fully automatic air cleaning system available

Flexible installation options

- suitable for tank, open channel or flow-cell installation
- range of handrail, wall or floor mounting kits
- suitable for saline applications

SEITA

Servicios Especializados de Ingeniería
en Tecnología y Automatización

www.seita.com.co

Power and productivity
for a better world™



Aztec ADS430

Optical dissolved oxygen probe

The Aztec 400 range

The Aztec 400 range of advanced digital sensors are designed for monitoring the key parameters in municipal and industrial water / wastewater treatment.

Featuring ABB's EZLink technology, the sensors offer plug-and-play measurement with ABB's latest digital transmitters to create the easiest-to-use and maintain monitoring systems on the market today.

Analysis and signal conditioning is conducted within the robust sensor housing and transmitted digitally to the transmitter.

The Aztec 400 range of digital sensors with EZLink offer:

- Plug-and-play digital sensor connection
- Automatic sensor recognition and set-up
- Advanced predictive maintenance diagnostics
- Enhanced measurement accuracy due to minimal electrical noise interference

ABB's latest range of digital transmitters featuring EZLink offer:

- Multiple sensor connection
- Data logging and graphical process trending
- Full audit trail capability
- SD card / USB stick data download capability
- Flexible communications including Ethernet, Profibus, MODBUS and analog outputs



Fig. 1: AWT440 transmitter

Aztec ADS430 RDO PRO-X optical dissolved oxygen sensor

The Aztec ADS430 optical dissolved oxygen sensor uses Rugged Dissolved Oxygen (RDO®) optical technology for measuring dissolved oxygen in the most demanding process environments including high saline applications. The robust construction resists abrasion and photobleaching effects that limit the lifetime of other optical DO sensors.

The Aztec ADS430 RDO PRO-X patented signal processing ensures the fastest response time to changes in concentration and maintains stability, even in dynamically-changing conditions up to 50 mg/l dissolved oxygen.

To eliminate programming errors, the sensor cap is pre-loaded with factory calibration coefficients, serial number, lifetime indication and manufacture date enabling long term deployment without the need for on-site calibration.

Analysis and signal conditioning is conducted within the robust sensor housing and transmitted digitally to the transmitter.

Featuring ABB's EZLink technology, users of this system benefit from plug-and-play connectivity, automatic sensor recognition / set-up and predictive diagnostics.

Applications

Typical applications for the Aztec ADS430 RDO PRO-X dissolved oxygen sensor include:

- Municipal and industrial water and wastewater treatment
- Food and beverage process control
- Aquaculture control

Accurate and reliable measurement

The Aztec ADS430 RDO PRO-X uses the latest advancements in optical measurement technology to provide an extremely stable and accurate measurement system that maintains calibration and operates without drift. This enables the system to operate continuously for up to 24 months. The advanced diagnostics notifies users of maintenance requirements, resulting in the lowest cost-of-ownership.

Measuring principle

When the Aztec ADS430 RDO PRO-X initiates a reading, an LED emits blue light that excites the lumiphore molecules within the sensor cap. Excited lumiphore molecules emit red light that is detected by a photodiode.

Oxygen molecules quench the excited lumiphore molecules and prevent the emission of red light; this process is called 'dynamic luminescence quenching'.

The Aztec ADS430 RDO PRO-X sensor measures the phase shift between the returned red light from the excited lumiphore molecules and red light from a red reference LED to calculate luminescence lifetime.

As the relationship between the dissolved oxygen concentration and the returned red light is inversely proportional, the sensor is able to calculate the dissolved oxygen concentration accurately.

A titanium temperature sensor is fitted in the body of the probe to compensate for changes in process temperature.

Dissolved oxygen determination by luminescence quenching has a linear response over a broad range of concentrations and offers a high degree of accuracy and stability.

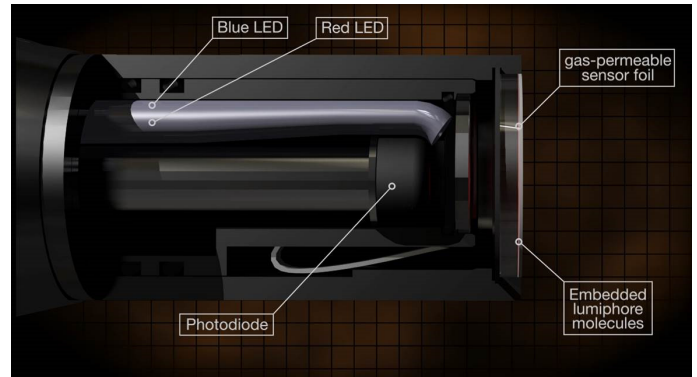

Fig. 2: Overview of ADS430 sensor

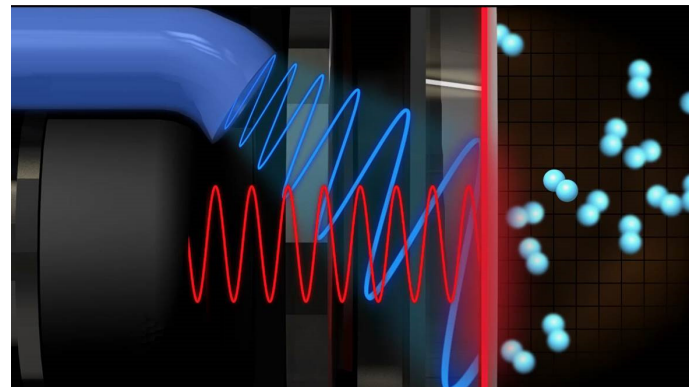

Fig. 3: Lumiphore molecules are excited by blue light causing them to emit red light that is detected by the photodiode

Aztec ADS430

Optical dissolved oxygen probe

Fast response

The patented signal processing within the Aztec ADS430 RDO sensor enables up to 5 times faster response times to changes in process conditions than other optical systems; delivering improved process control and maximum process savings.

Withstands harsh conditions

The abrasion-resistant sensing element withstands fouling, high sediment loads and rapid flow rates. The lumiphore is not affected by photobleaching or stray light. In addition, unlike membrane-based sensors, the Aztec ADS430 RDO sensor is unaffected by sulfides, sulfates, hydrogen sulfide, carbon dioxide, ammonia, pH, chloride and other interferences.

The Aztec ADS430 RDO Pro-X sensor is constructed from inert, non-corrosive materials making it suitable for use in high-salinity environments.

EPA-approved technology

The US Environmental Protection Agency (EPA) has approved RDO methods for use in their Clean Water Act programs.

NPDES permit holders can use the Aztec ADS430 RDO PRO-X sensor for monitoring influent, effluent and treatment processes.

Known interferences

There are some known interferences such as: alcohols > 5 %; hydrogen peroxide > 3 %; sodium hypochlorite (commercial bleach) > 3 %; gaseous sulfur dioxide; gaseous chlorine. Organic solvents and certain petroleum-based hydrocarbons may swell the sensing element and destroy it. Examples include, but are not limited to, acetone; chloroform; methylene chloride and BTEX (benzene, toluene, ethylbenzene, xylene) compounds.

Easy-to-use and maintain

The Aztec ADS430 RDO PRO-X sensor features ABB's EZLink technology to provide plug-and-play measurement with ABB's latest digital transmitters. This has created the easiest-to-use and maintain monitoring system on the market today.

EZLink

- No wiring, no complicated sensor set-up or configuration; simply connect the sensor using the ESC and the transmitter configures the sensor set-up automatically.

No calibration required

- The Aztec ADS430 RDO PRO-X sensor is not susceptible to drift due to the use of a non-consumptive, non-reactive method of measurement.
- To eliminate programming errors, the sensor cap is pre-loaded with factory calibration coefficients, serial number, lifetime indication and date of manufacture. These are uploaded to the Aztec ADS430 sensor automatically; simply snap on the SmartCap and start measuring!



Fig. 4: Aztec ADS430 SmartCap

Minimal maintenance

The SmartCap enables continuous operation for up to 24 months. Advanced sensor diagnostics evaluate sensor performance to provide maintenance interval alerts.

In applications where high biofouling is expected, the Aztec ADS430 RDO sensor can be used with ABB's EZClean system that cleans the sensor surface automatically with a powerful jet of air.

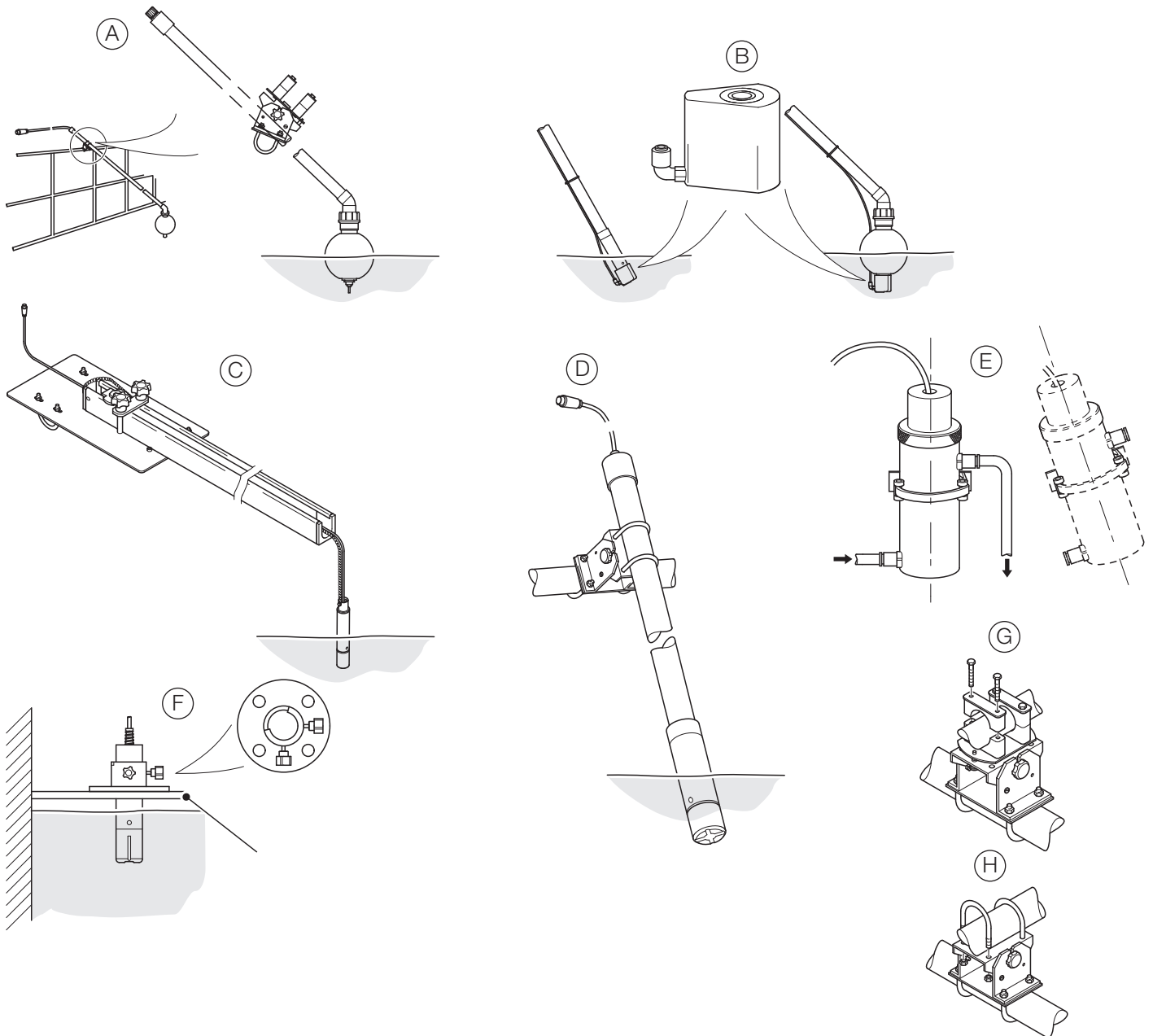

Fig. 5: ABB EZClean system

Aztec ADS430 Optical dissolved oxygen probe

Mounting options

ABB offer a range of mounting options for the Aztec ADS430 RDO sensor.



Item Mounting option

- Ⓐ Floating ball assembly: ADS430110 (including boom),
or
floating ball assembly kit: ADS430120 (excluding boom)
– suitable for handrail mounting using swivel / tilt
bracket Ⓔ or tilt bracket Ⓕ
- Ⓑ EZClean cleaning system: ADS430170
– shown fitted to dip pole and floating ball assembly
- Ⓒ Open channel and open tank mounting kit: ADS430140
– suitable for floor / wall (surface) mounting
- Ⓓ Dip / pole assembly: ADS430100 (including dip pole),
or
pole mounting adaptor kit: ADS430105
(excluding dip pole)
– handrail-mounted using tilt bracket Ⓕ

Item Mounting option

- Ⓔ Flowcell pipeline mount: ADS430160
– suitable for wall (surface) mounting
(includes wall mounting clip)
- Ⓕ Open tank flanged dip mount: ADS430150
– for mounting on user-supplied mounting bracket
- Ⓖ Handrail mounting bracket – swivel / tilt:
– ADS430130: for 42 mm (1.7 in.) handrail
– ADS430135: for 50 mm (2.0 in.) handrail
- Ⓗ Handrail mounting bracket – tilt (standard):
– ADS430125: for 42 mm (1.7 in.) handrail
– ADS430128: for 50 mm (2.0 in.) handrail

Aztec ADS430

Optical dissolved oxygen probe

Specification

Sensor type

Optical (luminescent) dissolved oxygen sensor

Probe

IP rating

IP68

Range

0 to 50 mg/l concentration; 0 to 600 % saturation

Accuracy

±0.1 mg/l, 0 to 8 mg/l

±0.2 mg/l, 8 to 20 mg/l

±10 % of reading, 20 to 50 mg/l

Resolution

0.01 mg/l

Response time

T90 < 45 sec; T95 < 60 sec @ 25 °C (77 °F)

Storage conditions

-5 to 60 °C (23 to 140° F)

Dimensions

47 mm (1.85 in.) diameter

203 mm (8 in.) length

Probe internal mounting thread

1¹/₄ NPT

Sensor cap

Typical working life

2 years

IP rating

IP68 (when fitted)

Storage conditions

1 to 60 °C (33° to 140° F) in factory container

Temperature sensor

Operating temperature range

0 to 50 °C (32 to 122° F)

Accuracy

±0.1 °C typical

Resolution

±0.01 °C

Power

Consumption (maximum)

50 mA @ 12 V DC

Measurement current

6 mA typical @ 24 V DC

Idle current (no measurement or consumption)

160 µA typical @ 24 V DC

Cable

Fixed length

10 m (39.3 ft.)

EZLink digital sensor connector IP rating

IP67 (when connected)

Extension cable (options)

1, 5, 15, 25, 50 m (3.2, 16.4, 49.2, 82, 164 ft.)

Maximum length (including optional extension cable)

Up to 210 m (826 ft.)

Salinity compensation

0 to 42 PSU (ppt)

Barometric pressure

506 to 1114 mbar (380 to 835 mm/Hg)

Environmental ratings

Pressure

10.342 bar (150 psi) from 0 to 50 °C (32 to 122 °F),

20.468 bar (300 psi) @ 25 °C (77 °F)

Operating temperature range

0 to 50 °C (32 to 122 °F)

Compliance

Heavy industrial, IEC:61000-6-2:2005

Methods

Standard methods 4S00-0

In-Situ methods 1002-8-2009, 1003-8-2009,

1004-8-2009 (EPA approved)

Materials of construction

Sensor cap

PC / PMMA

Probe body

ABS

Temperature sensor

Titanium

Cable

Polyurethane

Dimensions

All dimensions in mm (in.).

Probe

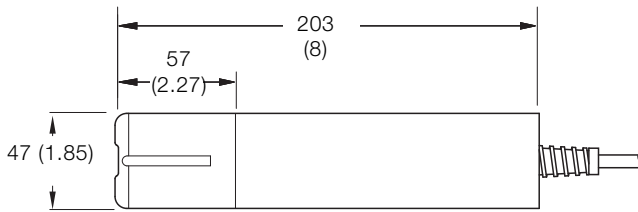

Accessories

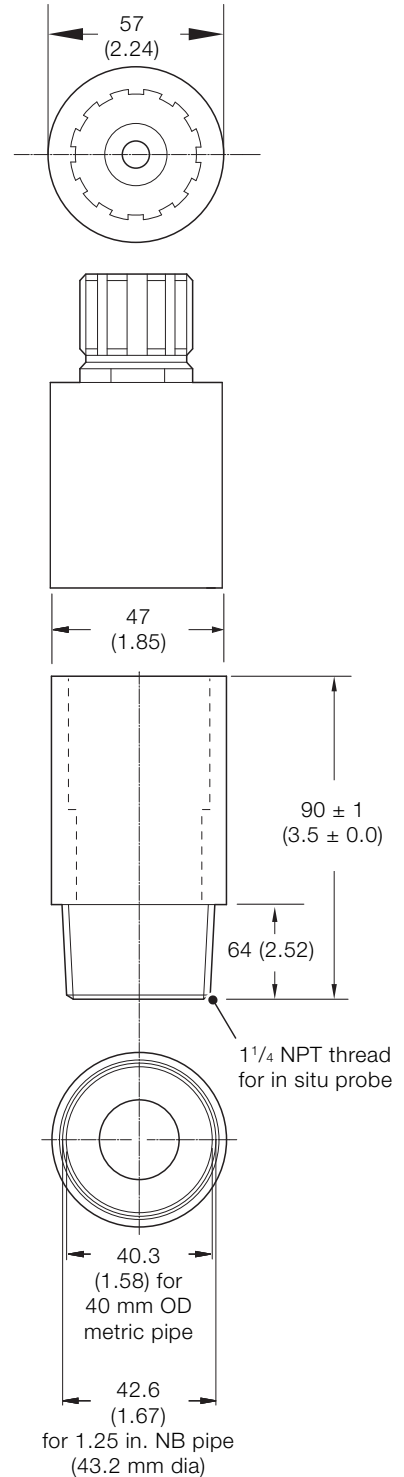
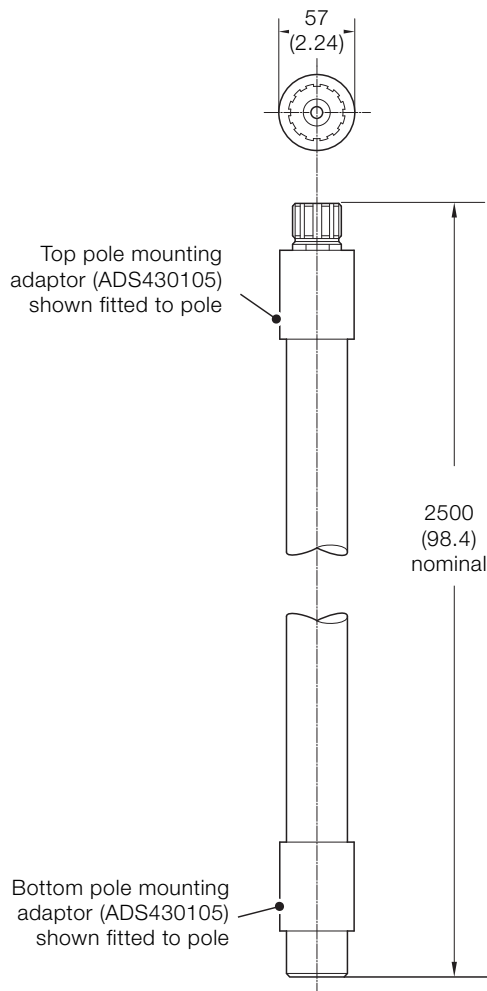

Fig. 6: ADS430100 dip pole assembly for in situ probe

Fig. 7: ADS430105 pole mounting adaptor kit

Aztec ADS430

Optical dissolved oxygen probe

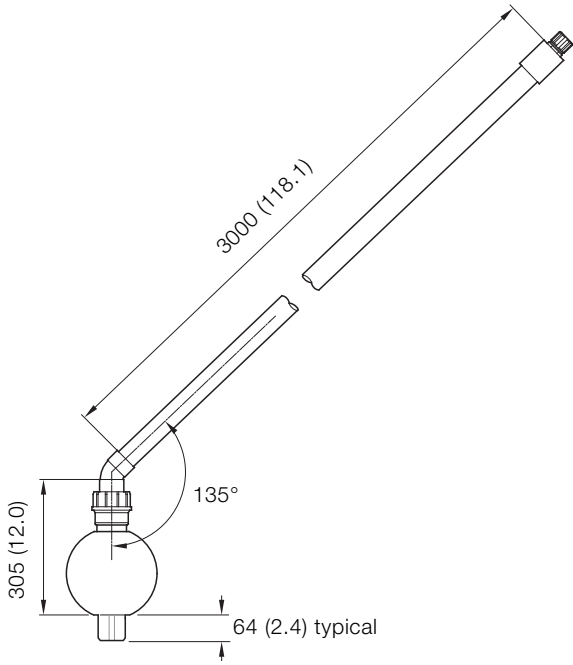
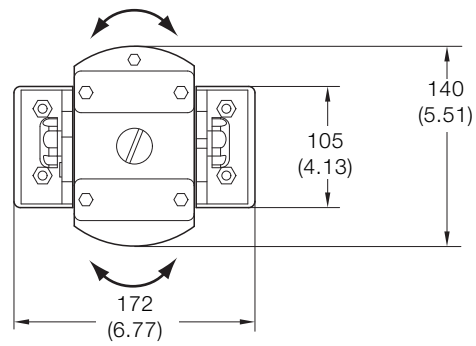
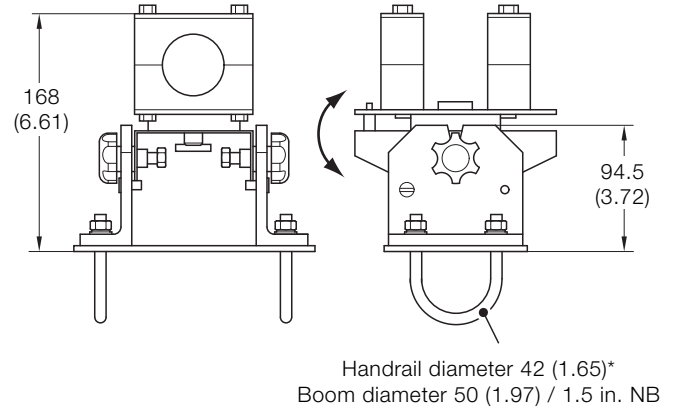
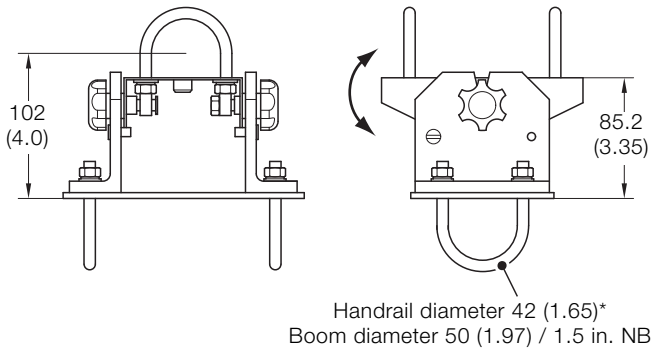

Fig. 8: ADS430110 floating ball assembly



*Handrail diameter is 50 mm (1.97) on part number: ADS430135

Fig. 10: ADS430130 floating ball mounting bracket assembly swivel version



Handrail diameter 42 (1.65)*
Boom diameter 50 (1.97) / 1.5 in. NB

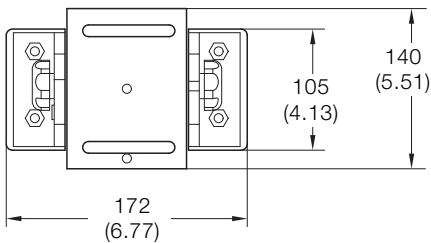

*Handrail diameter is 50 mm (1.97) on part number: ADS430128

Fig. 9: ADS430125 floating ball mounting bracket assembly

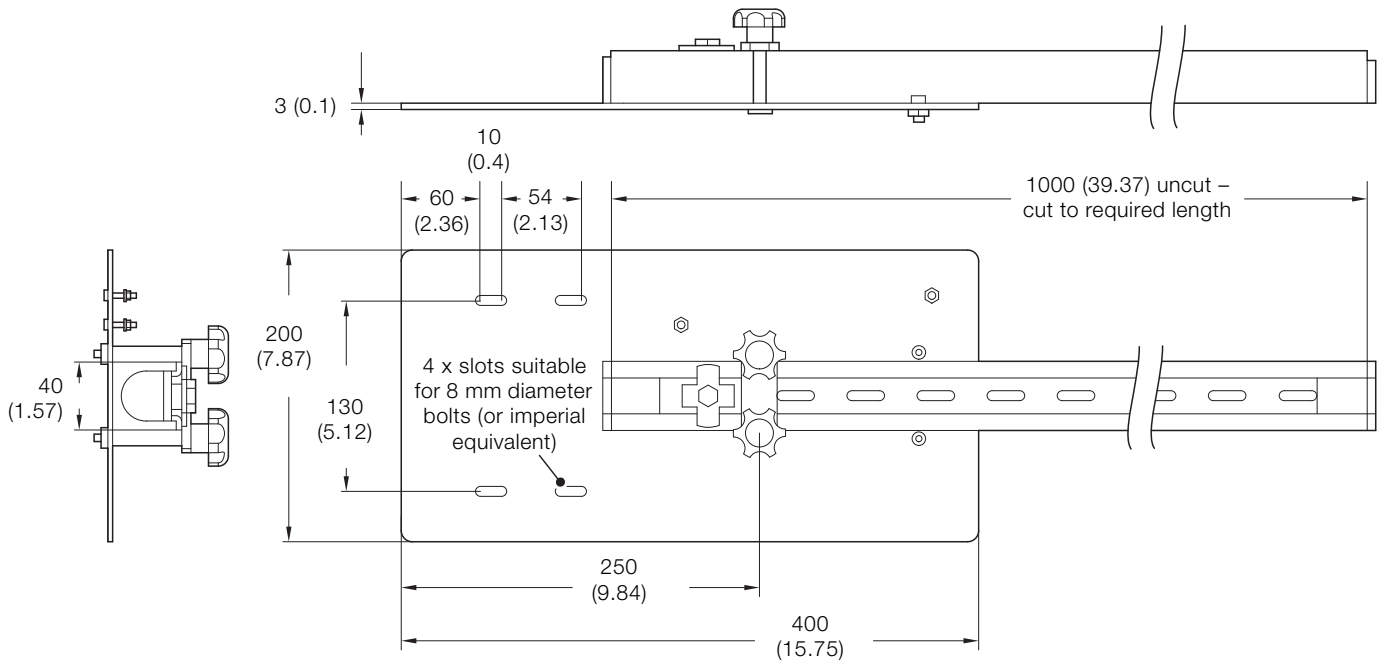

Fig. 11: ADS430140 open channel mounting kit

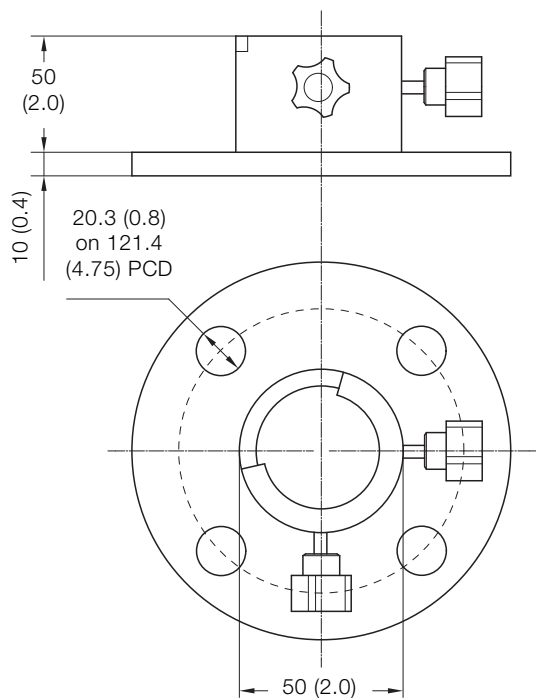

Fig. 12: ADS430150 open tank flanged dip mounting kit

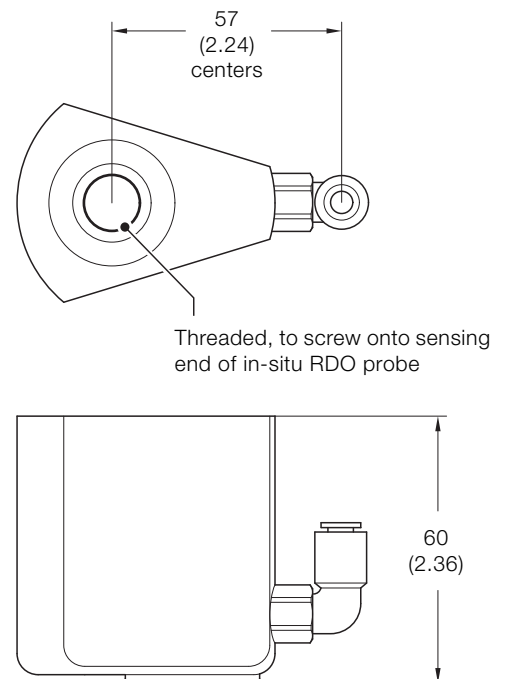

Fig. 13: ADS430170 EZClean adapter assembly

Aztec ADS430

Optical dissolved oxygen probe

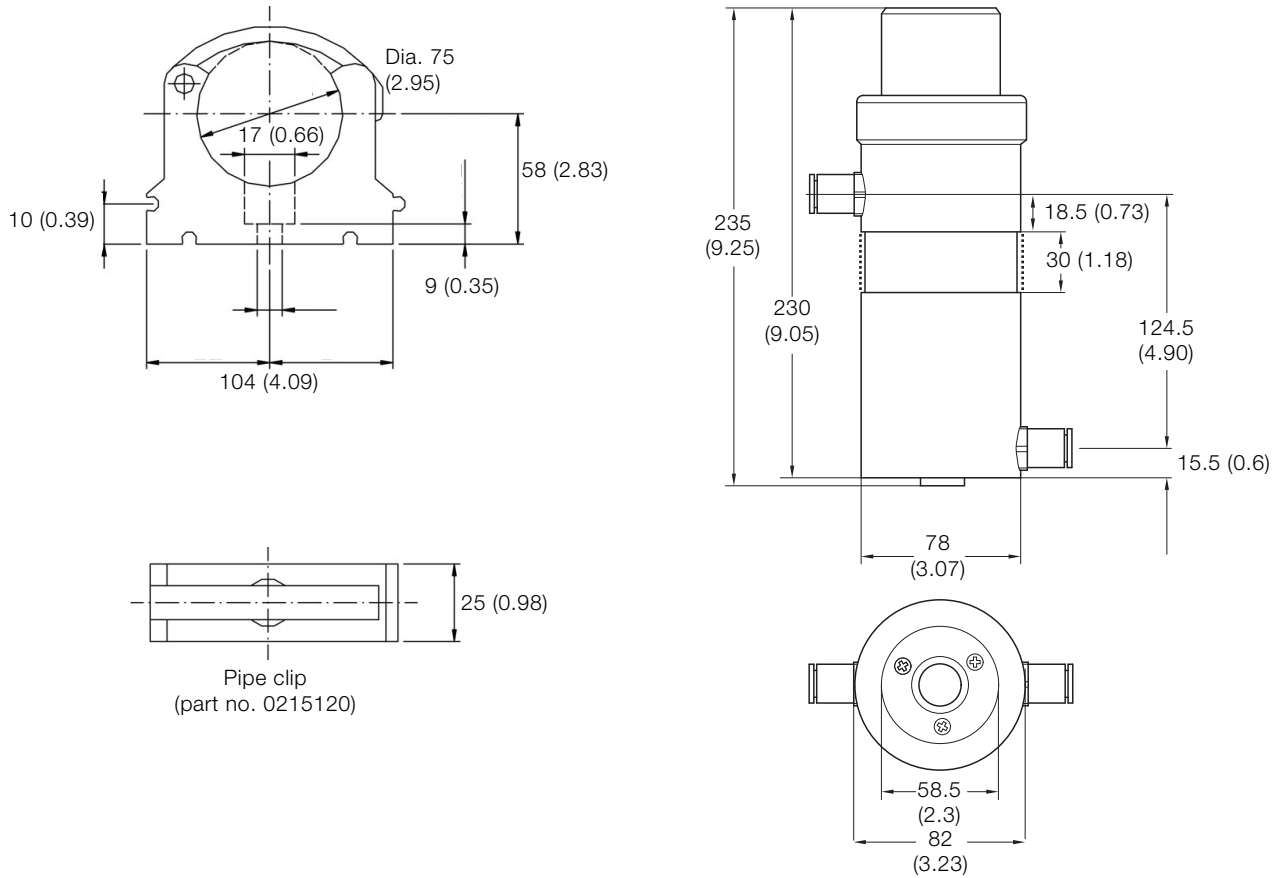
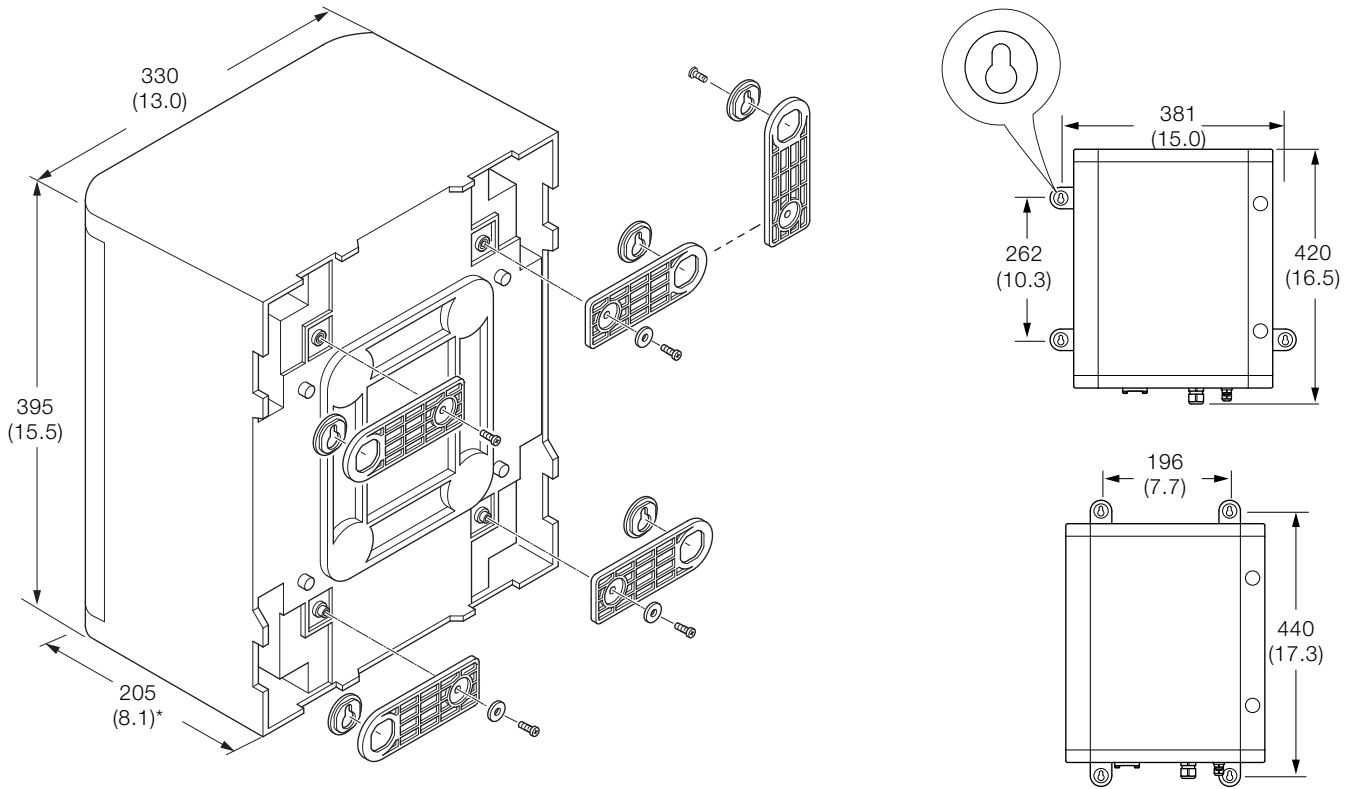

Fig. 14: ADS430160 flowcell pipeline mounting assembly

EZClean system

Dimensions in mm (in.)



*Add 280 (11.0) when door open

Fig. 15: Wall-mounting

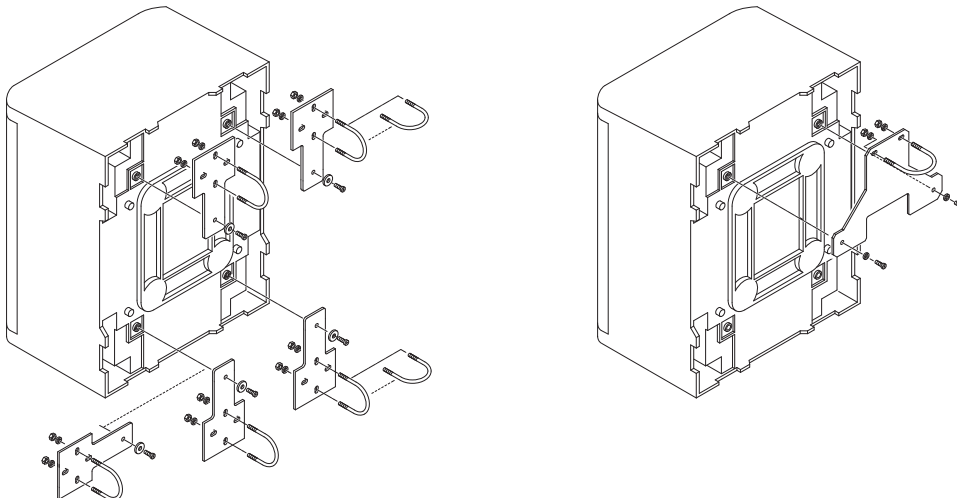

Fig. 16: Optional handrail and pole-mounting installations

Aztec ADS430

Optical dissolved oxygen probe

Ordering information

		Main code					Options			
Aztec ADS430 RDO® PRO-X optical dissolved oxygen sensing system		ADS430/	X	X	XX	XX	XX	XXX	XX	XX
Build revision										
Reserved		A								
Sensor type										
Optical (luminescent) dissolved oxygen sensor			1							
Probe attachment										
Not supplied						Y0				
Dip probe assembly supplied with 8.2 ft. (2.5 m) imperial pole						D1				
Dip probe mounting adapter kit for use with customer-supplied pole						D5				
Floating ball assembly supplied with 3 m (9.8 ft.) metric pole						B1				
Floating ball assembly kit for use with customer-supplied pole						B5				
Chain-mount adapter supplied with 3 m (9.8 ft.) of chain						C1				
Flowcell						F1				
Mounting accessories										
Not supplied						Y0				
Handrail mounting bracket for dip or floating ball systems (for use with 42 mm (1.7 in.) diameter handrail)						H1				
Handrail mounting bracket for dip or floating ball systems (for use with 50 mm (2.0 in.) diameter handrail)						H2				
Swivel-and-tilt action handrail mounting bracket for floating ball systems only (for use with 42 mm (1.7 in.) diameter handrail)						H3				
Swivel-and-tilt action handrail mounting bracket for floating ball systems only (for use with 50 mm (2.0 in.) diameter handrail)						H4				
Chain mounting bracket for use with chain-mount adapter						C1				
EZClean options										
Not supplied						Y0				
EZClean adapter (not suitable for flowcell installations)						A1				
EZClean system for dip, floating ball or chain-mount installations 230 V AC (supplied with compressor, adapter and tubing kit)						A2				
EZClean system for flowcell installations 230 V AC (supplied with compressor and tubing kit)						A3				
EZClean system for dip, floating ball or chain-mount installations 115 V AC (supplied with compressor, adapter and tubing kit)						A4				
EZClean system for flowcell installations 115 V AC (supplied with compressor and tubing kit)						A5				

See next page

Aztec ADS430 RDO® PRO-X optical dissolved oxygen sensing system	Main code					Options		
	ADS430/	X	X	XX	XX	XX	XX	XX
	See previous page							
Optional ordering code								
Add one or more of the following codes after the standard ordering information to select any additional options if required.								
Sensor extension cable								
EZLink digital sensor extension cable – 5 m (16.4 ft.)								E05
EZLink digital sensor extension cable – 10 m (32.8 ft.)								E10
EZLink digital sensor extension cable – 15 m (49.2 ft.)								E15
EZLink digital sensor extension cable – 25 m (82 ft.)								E25
EZLink digital sensor extension cable – 50 m (164 ft.)								E50
Documentation language (supplied as standard in English)								
German								M1
Italian								M2
Spanish								M3
French								M4
English								M5
Mounting options for EZClean system (supplied as standard with wall-mounting kit)								
EZClean handrail-mounting kit								G1
EZClean pole-mounting kit								G2

Acknowledgements

In-Situ and RDO are registered trademarks or trademarks of In-Situ Inc.

Contact us

ABB Limited

Process Automation

Howard Road, St. Neots
Cambridgeshire, PE19 8EU
UK

Tel: +44 (0)870 600 6122

Fax: +44 (0)1480 213 339

Mail: enquiries.mp.uk@gb.abb.com

ABB Inc.

Process Automation

125 E. County Line Road
Warminster, PA 18974
USA

Tel: +1 215 674 6000

Fax: +1 215 674 7183

www.abb.com

Note

We reserve the right to make technical changes or modify the contents of this document without prior notice. With regard to purchase orders, the agreed particulars shall prevail. ABB does not accept any responsibility whatsoever for potential errors or possible lack of information in this document.

We reserve all rights in this document and in the subject matter and illustrations contained therein. Any reproduction, disclosure to third parties or utilization of its contents in whole or in parts – is forbidden without prior written consent of ABB.

Copyright© 2016 ABB

All rights reserved

3KXA494430R1001



Sales



Service



Software